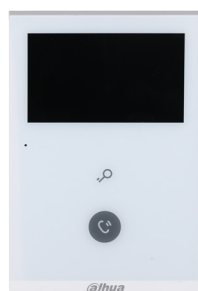

DHI-VTH5113H-W

2-wire Wi-Fi Hybrid Indoor Monitor

EACH

Technical Specification

System

Main Processor	Embedded Processor
Operating System	Embedded operating system
Network Protocol	IPv4;UDP;DNS;TCP

Basic

Screen Type	Capacitive Touchscreen
Display Screen	4.3" TFT
Screen Resolution	480 (H) × 272 (V)
Audio Compression	G.711a; G.711u; PCM
Audio Input	1 channel
Audio Output	Built-in speaker
Audio Mode	Two-way audio with VTO (half-duplex); Two-way audio with app (full-duplex)
Audio Enhancement	Echo suppression/digital noise reduction
Audio Bit Rate	16 kHz; 16 bit

Function

Leave Videos	Yes (SD card needed)
DND Mode	Do not disturb period can be set; Do not disturb mode can be set
Number of Extensions	5
Wi-Fi	Yes
Wireless Standard	IEEE802.11b/802.11g/802.11n
Wireless Frequency Range	2.4 GHz
Storage	Micro SD card (up to 64 GB)

- 4.3" TFT capacitive touch screen.
- Offers video intercom that communicates with VTOs through half-duplex, and the app through full-duplex.
- Supports recording videos and capturing snapshots. (SD card is required)
- 4-channel alarm input and 1-channel alarm output.
- The app can be used to receive calls and alarm notifications.
- Supports surface mount.
- Connects to HDCVI camera.



Port

RS-485	1
Alarm Input	4
Alarm Output	1 channel
Power Output	1 (12 V, 200 mA)
Door Bell	Yes (use the alarm input port)

Performance

Casing Material	PC + ABS
-----------------	----------

General

Appearance Color	White
Power Supply	2-wire controller
Power Adapter	Optional
Installation	Surface Mount
Certifications	CE
Accessory	Included: Power cord, alarm ribbon cable, bracket, branch terminal Sold separately: 2-wire controller
Product Dimensions	176.3 mm × 119.3 mm × 20.0 mm (6.94" × 4.70" × 0.79") (L × W × H)
Operating Temperature	-10 °C to +55 °C (+14 °F to +131 °F)
Operating Humidity	10%–95% (RH)
Operating Altitude	0 m–3000 m (0 ft–9842.52 ft)
Power Consumption	≤2.2 W (standby), ≤10 W (working)
Gross Weight	548.5 g (1.21 lb)

Ordering Information

Type	Model	Description
EACH Series	DHI-VTH5113H-W	2-wire Wi-Fi Hybrid Indoor Monitor
Accessories	VTNC1003C	2-wire Controller[sold separately]

Installation

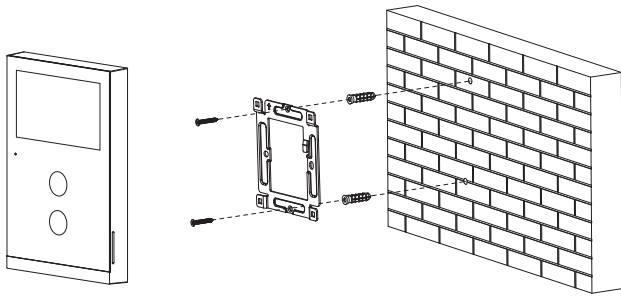

Dimensions (mm[inch])

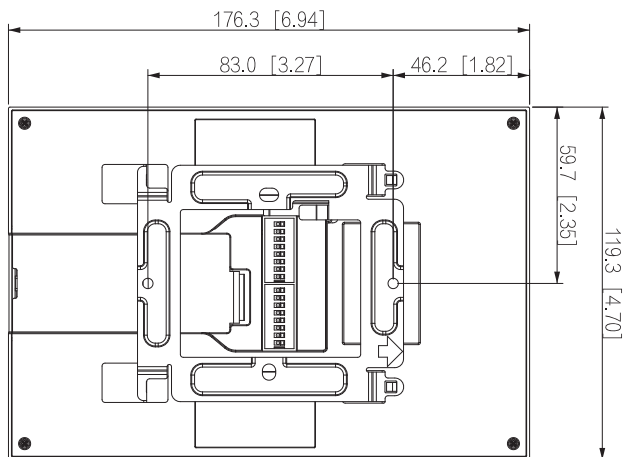
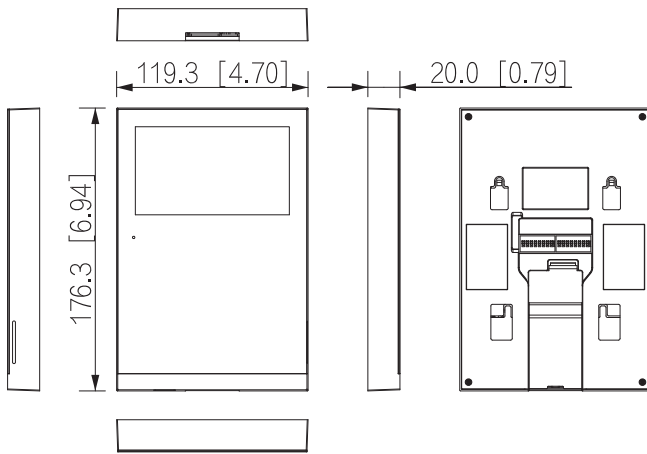

Application

